

# Multiple Generator Automatic Synchronising System

## Synchronising System Type Choice

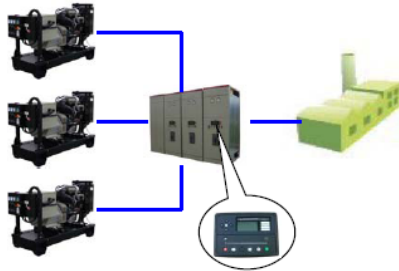

Independent Control Cabinet Type

### Independent Control Cabinet Type Feature:

**Functions:**

1. Independent control and bus bar cabinet;
2. Paralleling function (auto-tripping, closing, auto-paralleling, disconnection, auto-load shifting, distribution).

**Safety:**

1. Auto-tripping, closing;
2. Touch operation;
3. Fully auto control, avoiding misoperation by man.

**Humanized operation:**

Digital humanized operation interface.

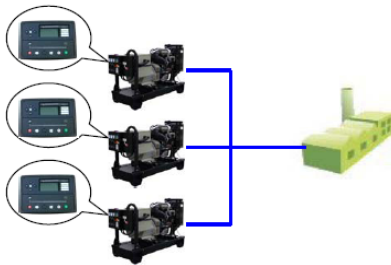

Simple Type

### Simple Type Feature:

**Functions:**

Paralleling function (auto-tripping, closing, auto-paralleling, disconnection, auto-load shifting, distribution).

**Safety:**

4. Auto-tripping, closing;
5. Touch operation;
6. Fully auto control, avoiding misoperation by man.

**Humanized operation:**

Digital humanized operation interface.



Parallel With Mains

DSE7520 Single generator no break solution

**Remark:**

The DSE7510(Deepsea) Controller as standard, BGC-L(Deif) optional.

## *Independent Control Cabinet Type*

### Introduction

A composite floor standing multi-bay control cubicle for automatic synchronization of multiple diesel generators set installation.

Each bay has a generator control and load switching section connected to a common bus bar.

The cubicles are manufacture with lockable hinged front door and removable aluminium gland plates to the top and base. Cable entry can be arranged for top and base entry. Lifting eyes are mounted on the top of the enclosure.



### Generator control section(s)

Automatic generator control module.

Microprocessor based and fully programmable with event logging and communications if required .

Features as follows:

Pushbuttons:

- Start
- Stop/reset
- Auto
- Manual
- Mute/lamp test

### LCD display (generator set )

- Voltage
- Amperage
- Frequency
- RPM
- Oil pressure
- Engine temperature
- Hours run
- Battery voltage

### LED/LCD display

- Charge fail
- Low oil pressure
- Underspeed
- Overspeed
- Fail to start
- Low battery voltage
- High battery voltage
- Fail to stop
- Under voltage
- Over voltage
- Under frequency
- Over frequency
- Reverse power
- CB closed

### Others display

Each control cubicle we installed frequency meter and voltage meter to monitor frequency and voltage of each generator set easy.

## Functions and protections:

- Reverse power
- Dead bus sensing
- Voltage matching
- Frequency matching
- Phase angle matching
- Ramp control
- Blend control
- Circuit breaker closing
- Engine speed control

## Dimensions

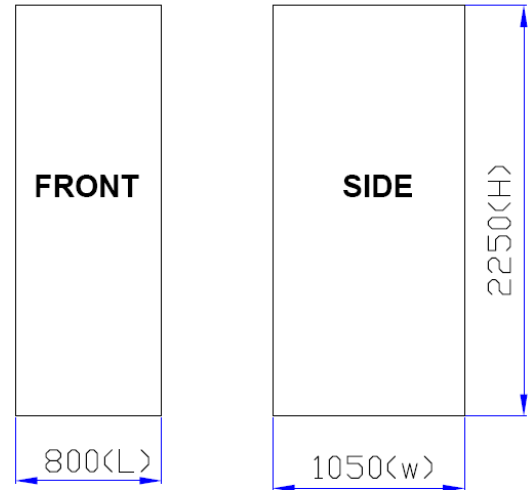

## Communications Dimensions

- RS232 link
- RJ45 link
- PC interface 100

Each cubicles dimension: 800(L) × 1050 (W) × 2250 (H)

Total length of control panel:

(Numbers of generator sets +1) × 800 (L)

## Controller choice:



DSE7510  
(standard)



BGC-L  
(optional)

# DSEPOWER® SHARING WITH SIMPLICITY.



## DSE7510

AUTO START CONTROL MODULE

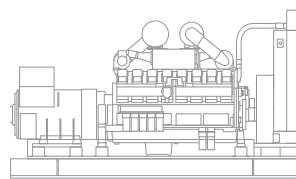

ELECTRONIC ENGINE CAPABILITY

The DSE7510 is an Automatic Engine Control Module, designed to provide advanced load share functionality for diesel and gas generating sets that include non-electronic and electronic engines. The module also provides excellent engine monitoring and protection features.

The module's load share functions include automatic synchronising with built in synchroscope and closing onto dead bus. Direct and flexible outputs from the module are provided to allow connection to the most commonly used speed governors and automatic voltage regulators (AVRs).

The module has been designed to combine a maximum of 16 generators and 16 mains (utility) supplies up to a maximum of 20 in one system, e.g. 16 generators and 4 mains (utility) supplies – DSE7560 required to synchronise with the mains (utility).

The module has the ability to monitor generator under/over volts, over current, generator under/over frequency, under speed, over speed, charge fail, emergency stop, low oil pressure, high engine temperature, fail to start, low/high DC battery volts, fail to stop, generator short circuit protection, reverse power,

generator phase rotation error, earth fault protection, loss of speed signal, fail to open, fail to close, out of sync, open circuit failure, negative phase sequence and loss of excitation.

### FEATURES

- Electronic engine capability
- RS232 or RS485 remote communications
- Modbus RTU
- Pin number protected front panel programming
- Exercise timer
- Back-lit LCD 4-line text display
- Multiple display languages
- Voltage measurement
- Configurable inputs (9)
- Configurable outputs (5)
- Automatic start
- Manual start
- Audible alarm
- LED indicators
- Built-in governor and AVR control
- Engine history event log
- Engine protection
- Fault condition notification to a designated PC
- Front panel mounting
- PC configuration
- Bus failure detection
- Configurable alarm timers
- Configurable start & stop timers
- Automatic load transfer
- SMS alert messaging
- Remote monitoring
- Magnetic pick-up
- kW overload alarms
- Engine temperature alarms

### LOAD SHARE FEATURES

- No-break transfer
- Peak shaving/peak lopping
- Sequential set start
- kW on mains (utility) level
- Mains (utility) decoupling test mode
- Manual speed/frequency adjust
- ROCOF & vector shift
- Generator load demand
- Automatic hours run balancing
- Dead bus sensing
- Existing load share line interfacing (P123 required)
- Direct governor & AVR communication
- Volts & frequency matching
- kW and kVA load sharing
- Manual voltage adjust
- Auto ID negotiation

### BENEFITS

- Sends SMS messages to engineers to notify specific engine problems (GSM Modem and SIM card required)
- On-site and remote (modem required) module configuration
- In-built engine diagnostics removes the requirement for service equipment
- Full engine protection & instrumentation without the need for additional senders (Electronic engines only)
- Remote monitoring of the module using comprehensive DSE PC software
- License free PC software

### SPECIFICATION

#### DC SUPPLY

8V to 35V continuous

#### CRANKING DROPOUTS

Able to survive 0V for 50mS, providing supply was at least 10V before dropout and supply recovers to 5V. This is achieved without the need for internal batteries

#### MAXIMUM OPERATING CURRENT

460mA at 12V. 245mA at 24V

#### MAXIMUM STANDBY CURRENT

375mA at 12V. 200mA at 24V

#### ALTERNATOR INPUT RANGE

15V AC (L-N) to 333V AC (L-N) absolute maximum

#### ALTERNATOR INPUT FREQUENCY

50Hz - 60Hz at rated engine speed (Minimum: 15V AC L-N)

#### MAGNETIC PICK-UP VOLTAGE RANGE

+/- 0.5V to 70V Peak

#### MAGNETIC INPUT FREQUENCY

10,000 Hz (max)

#### START RELAY OUTPUT

15A DC at supply voltage

#### FUEL RELAY OUTPUT

15A DC at supply voltage

#### AUXILIARY RELAY OUTPUTS

Three outputs 2A DC at supply voltage  
Two outputs volt free 2A at 250V AC

#### DIMENSIONS

240mm x 172mm x 57mm  
9.4" x 6.8" x 2.2"

#### PANEL CUTOUT

220mm x 160mm  
8.7" x 6.3"

#### CHARGE FAIL/EXCITATION RANGE

0V to 35V

#### BUILT IN GOVERNOR CONTROL

Fully Isolated  
Minimum Load Impedance: 1000Ω  
Gain Volts 0V - 10V DC  
Offset Volts + / - 10V DC

#### BUILT IN AVR CONTROL

Fully Isolated  
Minimum Load Impedance: 1000Ω  
Gain Volts 0V - 10V DC  
Offset Volts + / - 10V DC

#### ENCLOSURE PROTECTION

(front of module)  
IP65 (with optional gasket)  
IP42 (without gasket)

## ENVIRONMENTAL TESTING STANDARDS

### ELECTRO MAGNETIC COMPATIBILITY

BS EN 61000-6-2  
EMC Generic Immunity Standard for the Industrial Environment  
BS EN 61000-6-4  
EMC Generic Emission Standard for the Industrial Environment

### ELECTRICAL SAFETY

BS EN 60950  
Safety of Information Technology Equipment, including Electrical Business Equipment

### TEMPERATURE

BS EN 60068-2-2  
Test Ab to +70°C 60068-2-2 Hot  
Test Ab to -30°C 60068-2-1 Cold

### VIBRATION

BS EN 60068-2-6  
Ten sweeps in each of three major axes  
5Hz to 8Hz @ +/-7.5mm, 8Hz to 500Hz @ 2gn

### HUMIDITY

BS 2011 part 2.1 60068-2-30  
Test Cb Ob Cyclic  
93% RH @ 40°C for 48 hours

### SHOCK

BS EN 60068-2-27  
Three shocks in each of three major axes  
15gn in 11mS

## OPERATION

The module is operated using the front STOP/RESET, MANUAL, AUTO and START push buttons. Three of these push buttons include an LED indicator. Additional push buttons provide LCD display scroll, lamp test, mute functionality and breaker control.

## TYPICAL LOAD SHARE APPLICATION

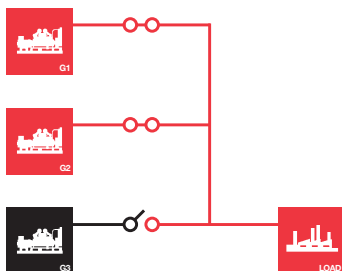

## TIMERS & INPUT FUNCTIONS

The module has been designed to include the following timers and input functions:

- Start delay timer
- Stop delay timer
- Crank timer
- Crank rest timer
- Engage attempt & manual crank limit timers
- Safety on delay timer
- Warm up timer
- Cooling timer
- Energise to stop hold timer
- Pre-heat timer
- Pre-heat bypass timer
- Smoke limiting control timer
- Fail to stop timer
- Over speed over-shoot timer
- Breaker pulse control timers
- DC battery alarm delay timers
- Sync/fail to sync timer

## BUILT-IN FUNCTIONS

- Alternator under/over volts
- Alternator under/over frequency
- Warning or shutdown on engine temperature, over/under speed, oil pressure
- Warning, shutdown or electrical trip on battery volts or over current
- Shutdown or electrical trip on reverse power, phase rotation or short circuit fault
- Earth fault shutdown
- Adjustable crank cycle/attempts
- Full remote control and telemetry
- 9 configurable digital inputs
- 5 configurable and 2 fixed relay/FET outputs
- System lock input
- Load switching control push-button inputs
- ROCOF/vector shift (mains/utility decoupling)
- Negative phase sequence
- Loss of excitation
- PIN number

## INSTRUMENTATION AND ALARMS

The DSE7510 module provides advanced metering and alarm functionality via the LCD display. The information can be accessed using the display scroll push buttons. The table below shows the instrumentation and alarm features the module provides.

Generator Volts L1-N, L2-N, L3-N  
Generator Volts L1-L2, L2-L3, L3-L1  
Generator Amps L1, L2, L3  
Generator Frequency Hz  
Generator kVA L1, L2, L3, Total  
Generator kW L1, L2, L3, Total  
Generator pf L1, L2, L3, Average  
Generator kVAh L1, L2, L3, Total  
Generator kWh  
Generator kVAh  
Generator kVAh  
Generator Phase Sequence  
Synchroscope Display  
Engine Speed RPM  
Engine Oil Pressure  
Engine Temperature  
Plant Battery Volts  
Charge Alternator Volts  
Fuel Level  
Generator Earth Current  
Bus Volts (L-L&LN)  
Bus Frequency (Hz)  
Bus Phase Sequence  
Engine Hours Run  
Number of Start Attempts  
Maintenance Display  
Engine ECU diagnostics information via industry standard CAN interface  
Enhanced metering via CAN when connected to an electronic engine

## TELEMETRY

The module gives the user full telemetry facilities when using the optional communications software. The module can be connected to a PC using the DSE810 PC interface or by using a suitable modem.

The PC software is Microsoft Windows™ based. All access into the module can be configured to become password protected to prevent unauthorised entry. The PC software allows the module to be controlled from a remote location.

## COMMUNICATIONS

The DSE7510 has a number of different communication capabilities:-

### SMS Messaging

When the module detects an alarm condition, it has the ability to send an SMS message to a dedicated mobile number, notifying an engineer of the problem. (GSM Modem and data enabled SIM Card required).

### Remote Communications

When the module detects an alarm condition, it dials out to a PC notifying the user of the exact alarm condition (modem required).

### Building Management

The module has been designed to be integrated with new and existing building management systems.

### SCADA/PC Software

The module has the ability to be configured and monitored from a remote PC, using the DSE810 interface.

### EVENT LOG

The module includes a comprehensive event log that shows the 25 most recent alarm conditions and the date and time that they occurred. This function assists the user when fault finding and maintaining the generating set.

### EXPANSION MODULES

DSE123 Load Share Lines Interface Module  
DSE157 Relay Output Expansion Module  
DSE545 & DSE548 Remote Annunciation Expansion Module  
DSE130 Input Expansion Module

### ELECTRONIC ENGINE COMPATIBILITY

- Cummins
- Deutz
- John Deere
- MTU
- Perkins
- Scania
- Volvo
- Isuzu
- Generic
- Plus additional manufacturers

# DSE7510

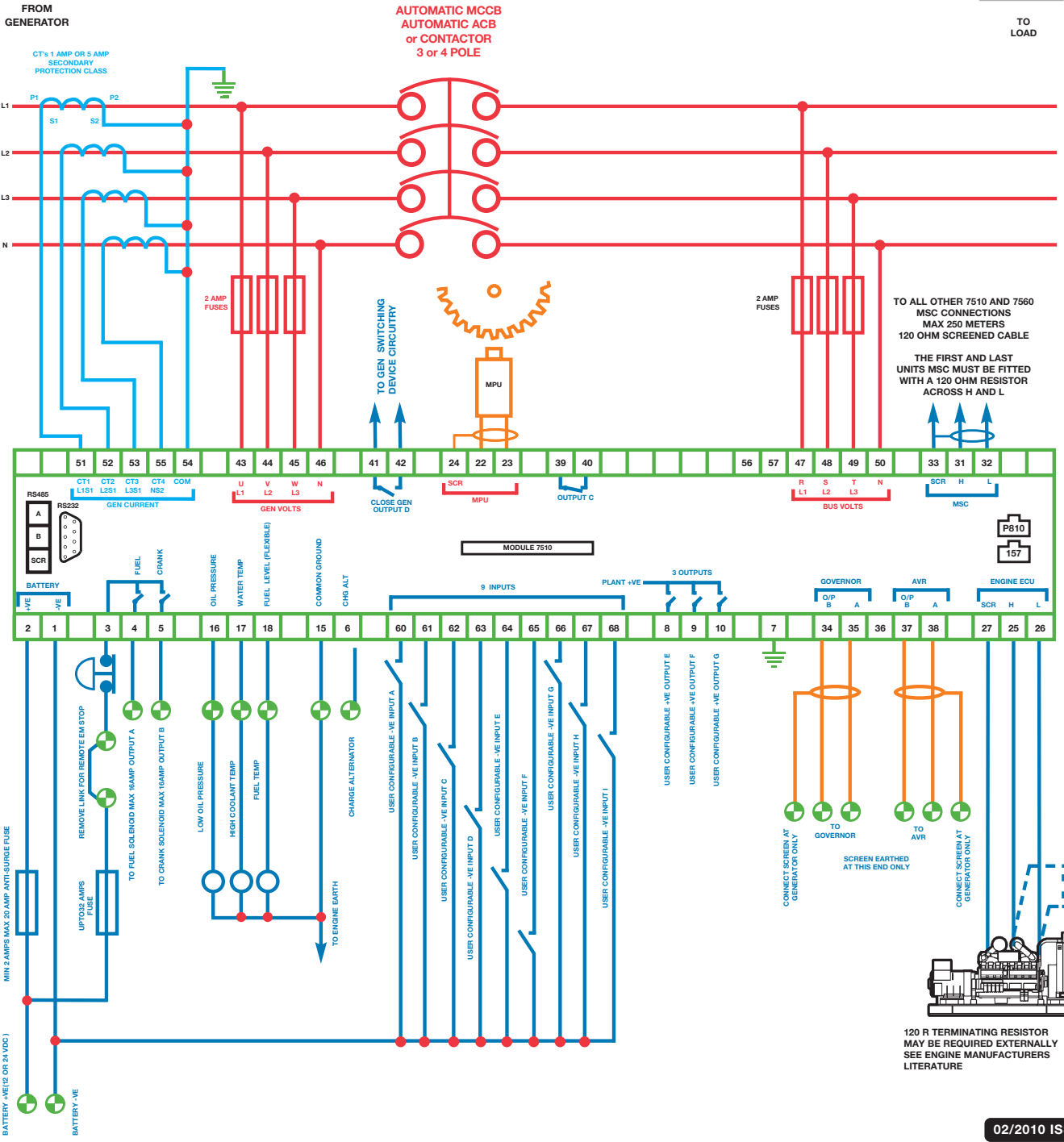

02/2010 ISSUE 5

- RELATED MATERIALS**
- |                                   |
|-----------------------------------|
| <b>TITLE</b>                      |
| DSE7510 Manual                    |
| DSE7510 Installation Instructions |
| DSE75xx PC Software Manual        |
| DSE7520 Data Sheet                |
| DSE7560 Data Sheet                |

- PART NO'S**
- |         |
|---------|
| 057-088 |
| 053-052 |
| 057-078 |
| 055-066 |
| 055-067 |

- DSE123 Data Sheet
- Load Share Design and Commissioning
- Guide to Synchronising and Load
- Sharing
- CAN and DSE Wiring Guide
- DSE850 Comms Software Data Sheet

- |           |
|-----------|
| 055-044   |
| 057-047   |
| 057-045/6 |
| 057-004   |
| 055-072   |

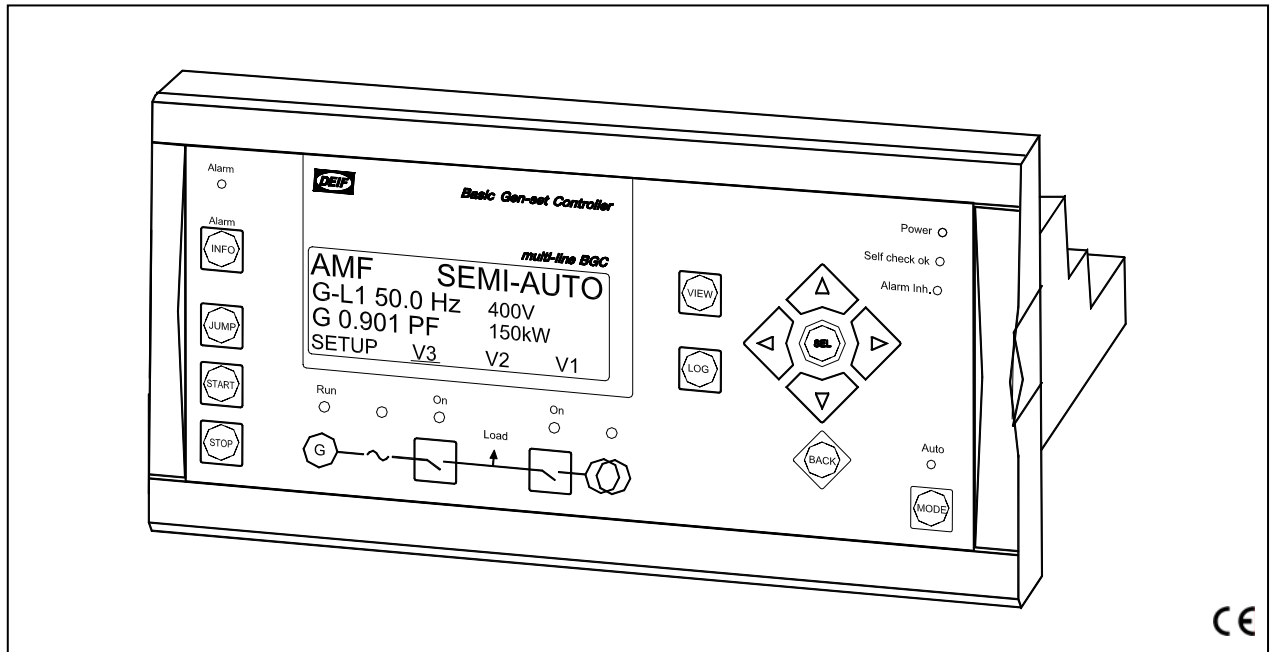

### Standard functions

#### **Automatic mains failure**

- Engine start up
- From mains to generator supply at a mains failure
- From generator to mains supply at mains return

#### **Island operation**

- Semi-automatic control of the gen-set
- Semi-automatic control of the breakers

#### **Time dependent start/stop**

- Automatic gen-set and breaker control
- 8 different start/stop commands

#### **Engine control**

- Start preparation
- Start/stop sequences
- Fuel solenoid selection (coil type)

#### **Protection (ANSI)**

- Overcurrent, 2 levels (51)
- Reverse power (32)
- 3 configurable VDO inputs
- 5 configurable binary inputs

#### **Generator and mains breaker**

- Contactor (constant signal)
- Circuit breaker (400 ms pulse)

**Application**

The Basic Gen-set Controller is a micro-processor based control unit containing all necessary functions for protection of a gen-set and control of mains and generator breaker. It contains all necessary 3-phase measuring circuits and all values and alarms are presented on the LCD display.

The BGC is a compact all-in-one unit designed for the following applications:

1. Automatic mains failure (no back sync.)
2. Island operation

Optional applications:

3. Multiple gen-sets, load sharing
4. Peak shaving
5. Fixed power to mains
6. Automatic mains failure (back sync.)

The BGC automatically carries out a cyclical self-test at start-up. If any errors are found, they will be displayed in clear text in the display.

The generator and mains breaker types can be configured to be either a circuit breaker or a contactor. Speed governor control and automatic voltage regulation are optional functions.

**Setup**

Setup is easily done via a menu structure in the display (password protected, 3 levels) or via the RJ45/RS232 PC connection and the multi-line 2 Windows® based PC utility software. The PC interface box needed for this operation is optional equipment for the BGC. The utility software offers additional features such as monitoring of all relevant information during commissioning, saving and downloading of settings and downloading of software updates.

**Options**

In order to perfectly match the product solution to specific applications, the functionality of the BGC can be equipped with a number of available options. The options selected by the customer will be integrated in the standard BGC hereby securing the same user interface unaffected by whether the application needs a highly complex or a more basic gen-set controller.

**Single line application diagrams**

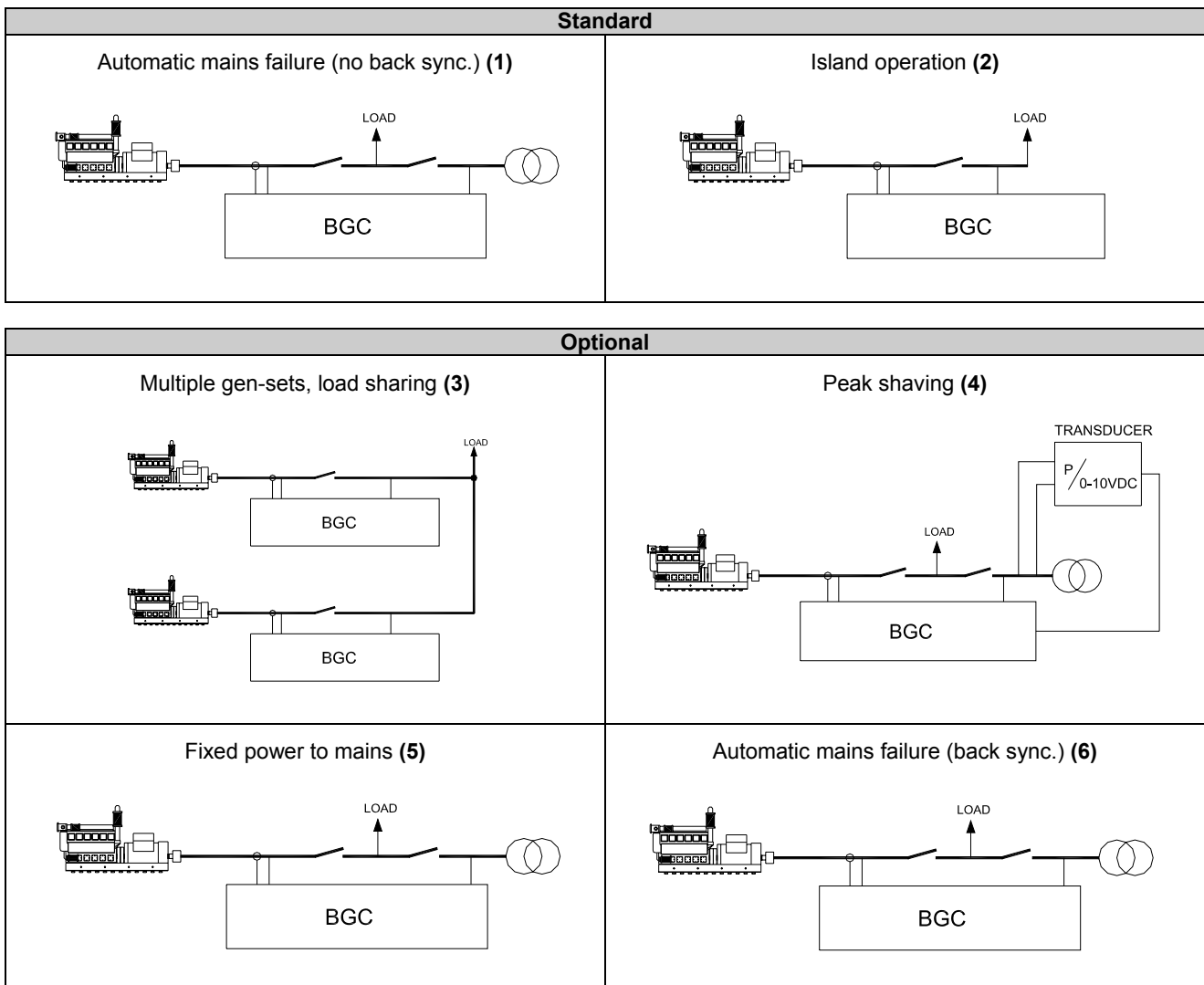

## Available options



Due to the fact that the BGC is limited to two option slots, there is an upper limit of two hardware options per unit (except G2 + G3). Please visit [www.deif.com](http://www.deif.com) or contact us directly for detailed information about available options.

Option	Description	Type	Note
<b>A</b>	<b>Loss of mains protection package</b>		
A1	over- and undervoltage (generator and busbar/mains) (27/59) over- and underfrequency (generator and busbar/mains) (81) vector jump (78) df/dt (ROCOF) (81)	Software option	
A2	over- and undervoltage (generator and busbar/mains) (27/59) over- and underfrequency (generator and busbar/mains) (81) df/dt (ROCOF) (81)	Software option	
A3	over- and undervoltage (generator and busbar/mains) (27/59) over- and underfrequency (generator and busbar/mains) (81) vector jump (78)	Software option	
<b>B</b>	<b>Generator/busbar/mains protection package</b>		
B1	over- and undervoltage (generator and busbar/mains) (27/59) over- and underfrequency (generator and busbar/mains) (81)	Software option	
<b>C</b>	<b>Generator add-on protection package</b>		
C1	over- and undervoltage (generator) (27/59) over- and underfrequency (generator) (81) overload (32) peak current current unbalance voltage asymmetry reactive power import (excitation loss) reactive power export (overexcitation)	Software option	
<b>D</b>	<b>Voltage/var/PF control</b>		
D1	Selection between: constant voltage control (stand-alone) constant reactive power control (parallel with mains) constant power factor control (parallel with mains) reactive load sharing (island paralleling with other generators)	Software option	Selection between: D1A: Analogue control D1R: Relay control Requires option M14
D2	constant voltage (stand-alone/sync.)	Software option	
<b>F</b>	<b>Analogue transducer outputs</b>		
F1	2 transducer outputs, 0...20mA or 4...20mA	Hardware option	
F2	4 transducer outputs, 0...20mA or 4...20mA	Hardware option	Two boards – no other hardware option available
<b>G</b>	<b>Control functions</b>		
G1	2 load dependent relays	Hardware option	Requires option M14
G2	synchronising with analogue lines	Hardware option	Two other hardware options available
G3	load sharing and synchronising	Hardware option	Two other hardware options available
<b>H</b>	<b>Serial communication</b>		
H1	Can-open	Hardware option	
H2	Modbus RTU	Hardware option	
H3	Profibus DP	Hardware option	
H4	CAT CCM	Hardware option	
H5	Can-bus engine communication for: MTU MDEC Detroit Diesel DDEC Deutz EMR John Deere JDEC Volvo Penta D12 AUX	Hardware option	
H6	Cummins ECM (RS485) engine communication	Hardware option	
<b>J</b>	<b>Cables</b>		
J5	BGC converter box kit	Other	
<b>K1</b>	<b>Designer's reference handbook (hard copy)</b>	Other	

## Available options (continued from page 3)

Option	Description	Type	Note
<b>M</b>	<b>Configurable I/O extension cards</b>		
M13	7 binary inputs, configurable	Hardware option	
M14	4 relay outputs	Hardware option	
M15	4 analogue inputs, configurable, 4...20mA	Hardware option	
<b>Y</b>	<b>Display layout</b>		
Y1	BGC display for island operation (no mains breaker)	Hardware option	

(ANSI# as per IEEE Std C37.2-1996(R2001) in parenthesis).